

# DESIGN NOTES

## 4 × 4 Video Crosspoint Has 100MHz Bandwidth and 85dB Rejection at 10MHz – Design Note 81

John Wright

### 4 × 4 Crosspoint

The compact high performance 4 × 4 crosspoint shown in Figure 1 uses four LT1205s to route any input to any or all outputs. The complete crosspoint uses only six SO packages, and less than six square inches of PC board space. The LT1254 quad current feedback amplifier serves as a cable driver with a gain of 2. A ±5V supply is used to ensure that the maximum 150°C junction temperature of the LT1254 is not exceeded in the SO package. With this supply voltage the crosspoint can operate at a 70°C ambient temperature and drive 2V (peak or DC) on to a double-terminated 75Ω video cable. The feedback resistors of these output amplifiers have been optimized for this supply voltage. The -3dB bandwidth of the crosspoint is over 100MHz with only 0.8dB of peaking. All Hostile Crosstalk Rejection is 85dB at 10MHz when a shorted input is routed to all outputs. Keys to attaining this high rejection include:

1. Mount the feedback resistors for the surface mount LT1254 on the backside of the PC board.
2. Keep the (-) input traces of LT1254 as short as possible.

3. Route V<sup>+</sup> and V<sup>-</sup> for the LT1205s on the component (top) side and under the devices (between inputs and outputs).
4. Use the backside of the PC board as a solid ground plane. Connect the LT1205 device grounds and bypass capacitor's grounds as vias to the backside ground plane.
5. Surround the LT1205 output traces by ground plane and route them away from (-) inputs of the other three LT1254s.

Each pair of logic inputs labeled SELECT LOGIC OUTPUT is used to select a particular output. The truth table is used to select the desired input, and is applied to each pair of logic inputs. For example, to route Channel 1 Input to Output 3, the fourth pair of logic inputs labeled SELECT LOGIC OUTPUT 3 is coded A = Low and B = High. To route Channel 3 Input to all outputs, set all 8 logic inputs High. Channel 3 is the default input with all logic inputs open. To shut off all channels, a pair of LT1259s can be substituted for the LT1254. The LT1259 is a dual current feedback amplifier with a shutdown pin that reduces the supply current to 0μA.

4 × 4 Crosspoint All Hostile Crosstalk

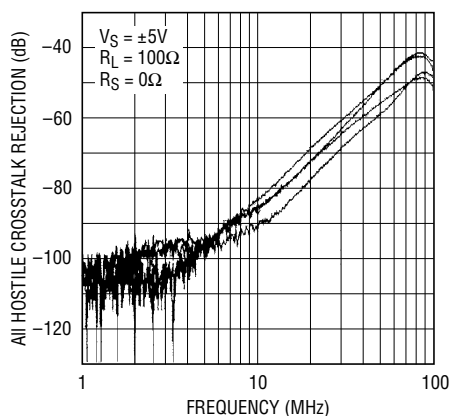

DN81 G01

4 × 4 Crosspoint Response

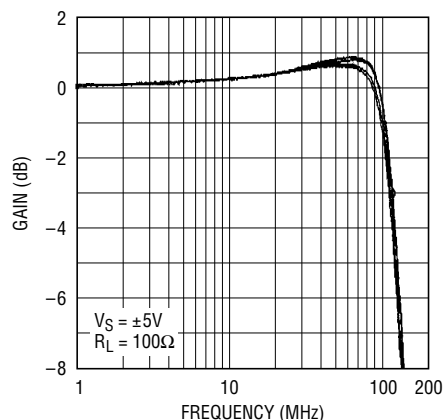

DN81 G02

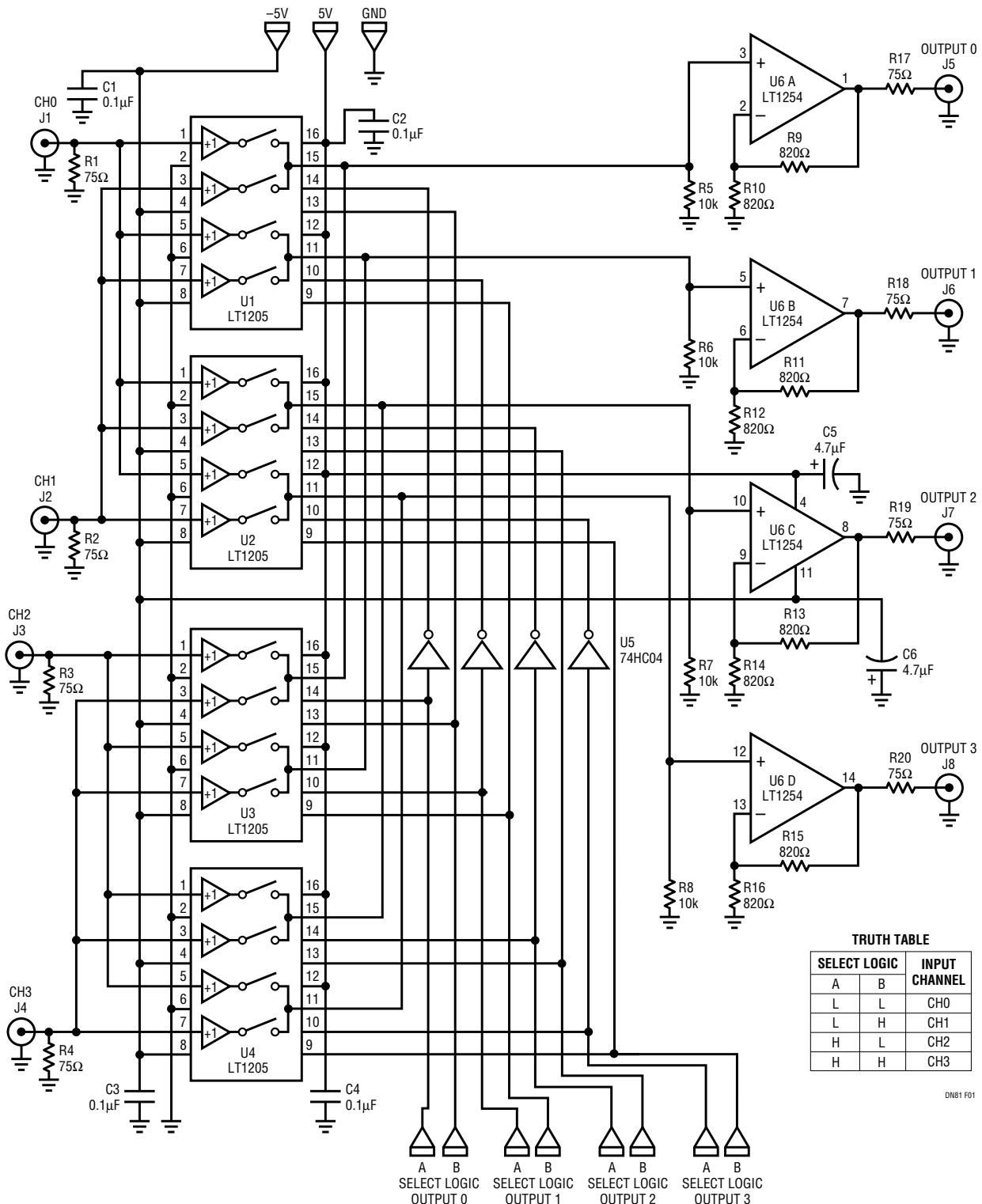

Figure 1. 4 × 4 Crosspoint and Truth Table

For literature on our High Speed Amplifiers, call 1-800-4-LINEAR. For applications help, call (408) 432-1900, Ext. 456